

# Aicube--Care with Love



**Price: USD 135 per unit**

PRODUCT DETAILS	
Type	SHOWER SEAT
Item Code	SA-B450
Range	Shower seat
Materials	1.Metal part constructed with super solid aluminum . 2. Seat part is super quality sylvestris pine plus nano-coated 3. Anti-slip surface of wood top
Finish	Bright Chrome Track and bracket/Seat Natural pin wood

### Technical Details and Descriptions:

Wall mounted shower seat foldable, Height adjustable.  
Certified Weight loading 150kgs  
Maximum user mass (seat): 225 kg.

### Standard and Warranty

Standard	ISO17966
Warranty	Expected service life of the shower seat is 10 years, provided that maintenance is carried out correctly. We makes a commitment to remedy material and manufacturing defects for a period of 3 years from the invoicing date.

### Cleanning and Care Guide

- 1.The product is to be cleaned with hot water or a mild soapy cleaning agent.
  2. We recommend that chalky deposits be removed from aluminum parts using a solution of 3:7 acetic acid: tap water. When the aluminum parts have been washed down with this solution, the parts must be wiped over with a damp cloth, wrung out in clear water. The product must be wiped down with a soft rag wrung out in clear water immediately after cleaning, as some materials may otherwise be discolored and stained, and the surface coating may deteriorate.
- Warm Note:** Do not use chlorine based, corrosive or abrasive cleaners as it may result in the surface being damaged.

Guangzhou SELAQUA Sanitary Ware Co., Ltd  
Jintian Industrial Park, Huadong Town,Huadu District,Guangzhou City,Guangdong Province, China.

[www.selaqua.com](http://www.selaqua.com);[www.aicubecare.com](http://www.aicubecare.com)

Contact: Katie Peng

Sales Manager

M:+86 18620266308

E: [katie@aicubecare.com](mailto:katie@aicubecare.com)

### IMAGE



### TECHNICAL DRAWINGS

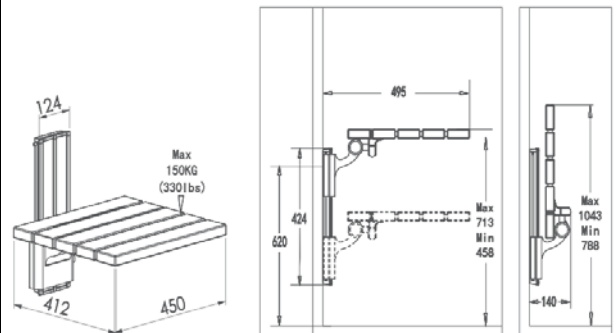

#### Shower Seat

Wall Mounted Flip-Up and Height adjustable

Solid Metal Wall Fixing

INCL. Stainless Steel Screws and Universal Wall Plugs

Ergonomical Seat made of super **high quality nano-coated sylvestris pine wood** material

Wide-450mm, Depth-495mm (refer to above drawings)

**Weight loading 150kgs certified.**

**Carton Size:58\*47\*17cm. Gross Weight: 7.31kgs**